

KITAZAWA

ANSI150 Ductile Iron Lug Type Butterfly Valve

Fig: FF150LU-L

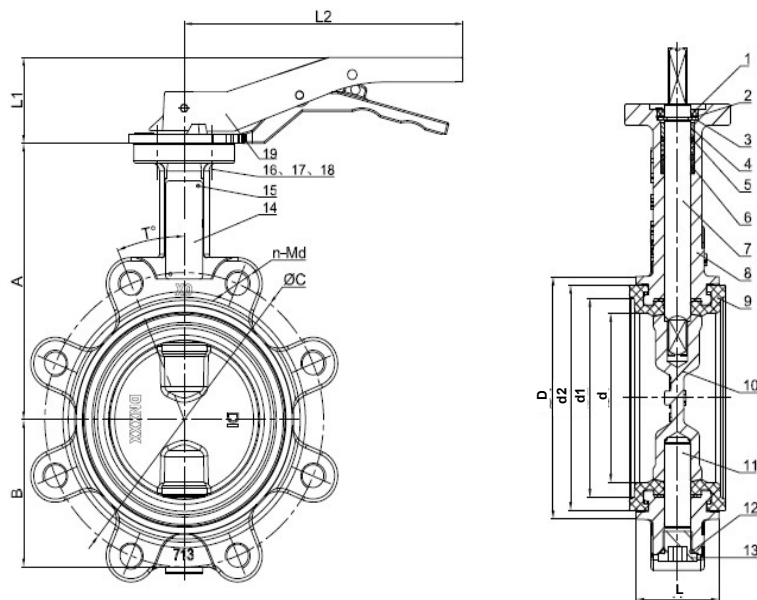

MATERIALS

NO	NAME OF PART	QTY	MATERIALS
1	DUST SEAL	1	NBR
2	SNAP RING	1	65Mn
3	U-RING	1	STAINLESS STEEL
4	BEARING	1	COOPER
5	O-RING	2	NBR
6	BEARING	1	GLASS FIBER+F4
7	STEM	1	STAINLESS STEEL
8	BODY	1	DUCTILE IRON+EPOXY COATING
9	SEAT RUBBER	1	EPDM
10	DISC	1	DUCTILE IRON+EPOXY COATING
11	BOTTOM STEM	1	STAINLESS STEEL
12	O-RING	1	NBR
13	PLUG	1	CARBON STEEL+Cr PLATING
14	NAMEPLATE	1	ALUMINUM
15	RIVET	2	ALUMINUM
16	SET BOLT	1S	STAINLESS STEEL
17	NUT	1S	STAINLESS STEEL
18	WASHER	1S	STAINLESS STEEL
19	HANDLE	1	ALUMINUM

SPECIFICATION

- Ductile Iron Body
- Design According to BS EN 593
- Face to Face Dimension
Conforms to BS EN 558 20 series
- Flange Conforms to
ASME B16.5 CLASS 150
- Top flange: ISO 5211
- Nominal Pressure: 1.72MPa
- Working Temperature:
-10~100°C
- Suitable Medium: Water

⚠

- DO NOT USE FOR STEAM
- DO NOT USE UNDER FREEZE
- DO NOT USE FOR FLAMMABLE
- DO NOT USE FOR POISONOUS GAS APPLICATION
- WARRANTY ONLY APPLIES IN ASEAN

SIZE	DIMENSIONS(mm)										
DN	d	d1	d2	A	B	L1	L	C	n-M	D	L2
40	40	53	67	135	52	53	33	98.4	4-(1/2-13UNC)	75	180
50	50	62	76	140	60	53	43	120.7	4-(5/8-11UNC)	89	180
65	67	82	96	150	70	53	46	139.7	4-(5/8-11UNC)	107	180
80	80	101	115	156	86	53	46	152.4	4-(5/8-11UNC)	123	180
100	98	116	130	169	90	53	52	190.5	8-(5/8-11UNC)	141	180
125	125	145	159	190	105	53	56	215.9	8-(3/4-10UNC)	170	220
150	148	170	185	200	120	53	56	241.3	8-(3/4-10UNC)	196	220



Produced by KITZ VALVE & ACTUATION VIETNAM CO., LTD.

<https://kitz-kvv.com>

* All or part of the information listed on this sheet may be changed or removed without prior notice.