

# KITAZAWA

PN16 Ductile Iron Non Rising Stem Gate Valve

Fig: FG16FN

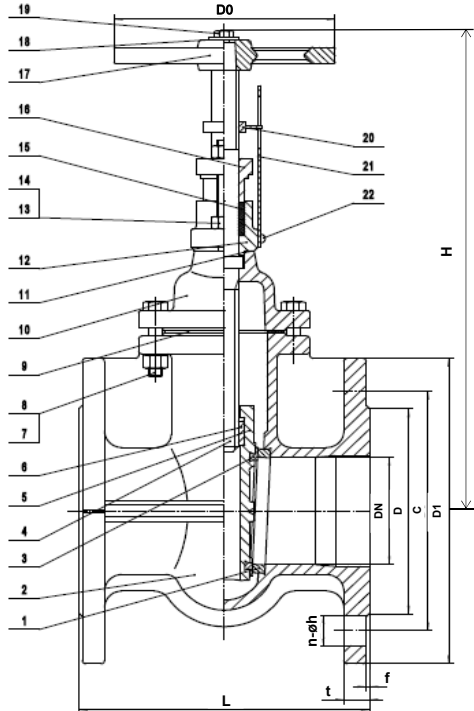

**SPECIFICATION**

- Ductile Iron Body
- Design According to DIN EN1171
- Face to Face Dimension Conforms to Series 14 of BS EN 558-1
- Flange Conforms to BS EN1092
- Nominal Pressure 1.6MPa
- Working Temperature: -10~120°C
- Suitable Medium: Water and Oil



- DO NOT USE FOR STEAM
- DO NOT USE UNDER FREEZE
- DO NOT USE FOR FLAMMABLE
- DO NOT USE FOR POISONOUS GAS APPLICATION
- WARRANTY ONLY APPLIES IN ASEAN

**MATERIALS**

NO	NAME OF PARTS	QTY	MATERIALS
1	BODY SEAT RING	2	CAST BRONZE
2	BODY	1	DUCTILE IRON
3	DISC SEAT RING	2	CAST BRONZE
4	STEM	1	STAINLESS STEEL
5	DISC	1	DUCTILE IRON
6	STEM NUT	1	CAST BRASS
7	BONNET BOLT	1S	STEEL
8	BONNET NUT	1S	STEEL
9	GASKET	1	GRAPHITE
10	BONNET	1	DUCTILE IRON
11	GASKET	1	RUBBER GRAPHITE
12	STUFFING BOX	1	DUCTILE IRON
13	GLAND BOLT	1S	STEEL
14	GLAND NUT	1S	STEEL
15	GLAND PACKING	1S	GRAPHITE
16	GLAND	1	DUCTILE IRON
17	HANDLE WHEEL	1	CAST IRON
18	WASHER	1	STEEL
19	WHEEL BOLT	1	STEEL
20	INDICATOR	1	ZINC ALLOY
21	PLATE	1	ALUMINUM
22	SCREW	1	STEEL

SIZE	DIMENSIONS(mm)								
DN	L	D1	C	D	t	f	n-øh	D0	H
50	150	165	125	99	16	2	4-19	160	296
65	170	185	145	118	16	2	4-19	160	334
80	180	200	160	132	17	2	8-19	160	378
100	190	220	180	156	17	2	8-19	200	444
125	200	250	210	184	18	3	8-19	200	527
150	210	285	240	211	20	3	8-23	250	603
200	230	340	295	266	21	3	12-23	250	758
250	250	405	355	319	23	3	12-28	320	909
300	270	460	410	370	24	4	12-28	320	1048



Produced by KITZ VALVE & ACTUATION VIETNAM CO., LTD.

<https://kitz-kvv.com>

\* All or part of the information listed on this sheet may be changed or removed without prior notice.