

# KITAZAWA

## PN25 Ductile Iron Y-Type Strainer

Fig: FY25F

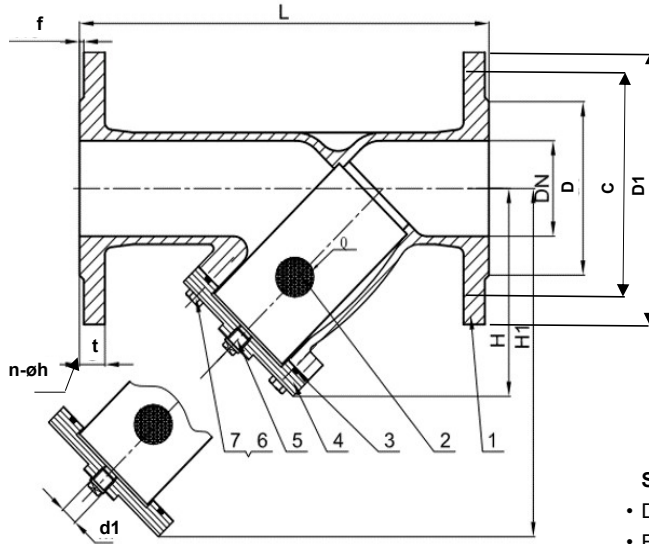

### SPECIFICATIONS

- Ductile Iron Body
- Face to Face Dimension  
Conforms to EN 558 1 series
- Flange Conforms to  
BS EN1092-2 PN16
- Nominal Pressure: 2.5MPa
- Working Temperature: -10-100°C
- Suitable Medium: Water

### MATERIALS

NO	NAME OF PART	QTY	MATERIALS
1	BODY	1	DUCTILE IRON+EPOXY COATING
2	SCREEN	1	STAINLESS STEEL
3	GASKET	1	EPDM
4	COVER	1	DUCTILE IRON+EPOXY COATING
5	PLUG	1	STAINLESS STEEL
6	WASHER	1S	STAINLESS STEEL
7	COVER BOLT	1S	STAINLESS STEEL



- DO NOT USE FOR STEAM
- DO NOT USE UNDER FREEZE
- DO NOT USE FOR FLAMMABLE
- DO NOT USE FOR POISONOUS GAS APPLICATION
- WARRANTY ONLY APPLIES IN ASEAN

SIZE	d1	DIMENSIONS(mm)								
		DN	BSPT	D1	C	D	t	f	n-øh	L
50	Rp1/2	165	125	99	19	3	4-19	230	117	192
65	Rp1/2	185	145	118	19	3	8-19	290	142	232
80	Rp1/2	200	160	132	19	3	8-19	310	163	265
100	Rp1/2	235	190	156	19	3	8-23	350	194	323
125	Rp1/2	270	220	184	19	3	8-28	400	248	402
150	Rp3/4	300	250	211	20	3	8-28	480	280	446
200	Rp3/4	360	310	274	22	3	12-28	600	352	560
250	Rp3/4	425	370	330	24.5	3	12-31	730	443	722
300	Rp3/4	485	430	389	27.5	4	16-31	850	480	785
350	Rp3/4	555	490	448	30	4	16-34	980	688	1158
400	Rp3/4	620	550	503	32	4	16-37	1100	854	1382



Produced by KITZ VALVE & ACTUATION VIETNAM CO., LTD.

<https://kitz-kvv.com>

\* All or part of the information listed on this sheet may be changed or removed without prior notice.